

Autonics Photoelectric Sensor BR SERIES INSTRUCTION MANUAL

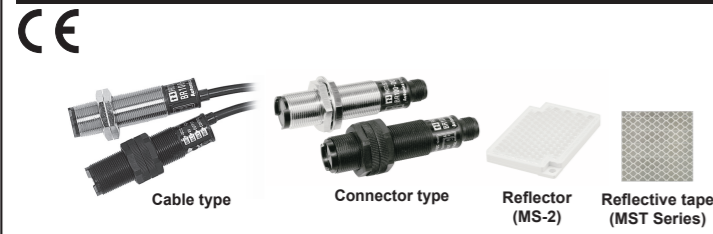

Thank you for choosing our Autonics product.
Please read the following safety considerations before use.

Safety Considerations

※Please observe all safety considerations for safe and proper product operation to avoid hazards.
※⚠ symbol represents caution due to special circumstances in which hazards may occur.

- Warning** Failure to follow these instructions may result in serious injury or death.
- Caution** Failure to follow these instructions may result in personal injury or product damage.

Warning

- Fail-safe device must be installed when using the unit with machinery that may cause serious injury or substantial economic loss. (e.g. nuclear power control, medical equipment, ships, vehicles, railways, aircraft, combustion apparatus, safety equipment, crime/disaster prevention devices, etc.)
- Do not disassemble or modify the unit.
- Do not connect, repair, or inspect the unit while connected to a power source.
- Check 'Connections' before wiring.

Caution

- Use the unit within the rated specifications.
- Use dry cloth to clean the unit, and do not use water or organic solvent.
- Do not use the unit in the place where flammable/explosive/corrosive gas, humidity, direct sunlight, radiant heat, vibration, impact, or salinity may be present.

Ordering Information

BR	P	100	-	T	D	T	-	C	-	P
Control output										
No mark NPN open collector output										
P PNP open collector output										
Connection										
No mark Cable type										
C Connector type										
Appearance										
No mark Integrated type										
1 Emitter										
2 Receiver										
Operation mode										
No mark Light ON/Dark ON switching										
L Light ON										
D Dark ON										
Optic properties										
No mark Standard type										
N Narrow beam reflective type										
Output type										
T Transistor output										
Power supply										
D DC power										
Sensing type										
T Through-beam type										
D Diffuse reflective type										
M Retroreflective type										
Sensing distance unit										
No mark mm										
M m										
Sensing distance										
Number Sensing distance										
Case material										
No mark Metal										
P Plastic										
Item										
BR Cylindrical type photoelectric sensor										

※This information is intended for product management of through-beam type.
(no need to refer when selecting model)

Operation Mode

Operation mode	Light ON	Dark ON
Receiver operation	Received light Interrupted light	Received light Interrupted light
Operation indicator (red LED)	ON OFF	ON OFF
Transistor output	ON OFF	ON OFF

※The transistor output will be held OFF for 0.5 sec after supplied power in order to prevent malfunction of this photoelectric sensor (except through-beam type).

※The above specifications are subject to change and some models may be discontinued without notice.
※Be sure to follow cautions written in the instruction manual and the technical descriptions (catalog, homepage).

Specifications

Model	BRP100 NPN open collector output (-C)	BR100 PNP open collector output (-C)	BRP400 NPN open collector output (-C)	BR400 PNP open collector output (-C)	BRP200 NPN open collector output (-C)	BR200 PNP open collector output (-C)	BRP3M-MDT(-C)	BR3M-MDT(-C)	BR4M-TD(-C)	BR20M-TD(-C)	BR4M-TD(-C)	BR20M-TD(-C)
Case	Plastic	Metal	Plastic	Metal	Plastic	Metal	Plastic	Metal	Metal	Metal	Metal	Metal
Sensing type	Diffuse reflective type		Narrow beam reflective type		Retroreflective type		Through-beam type					
Sensing distance	100mm ^{※1}		400mm ^{※2}		200mm ^{※2}		3m ^{※3}		4m		20m	
Sensing target	Opaque, translucent materials		Opaque materials of min. Ø60mm		Opaque materials of min. Ø60mm		Opaque materials of min. Ø15mm					
Hysteresis	Max. 20% at rated sensing distance											
Response time	Max. 1ms											
Power supply	12-24VDC ±10% (ripple P-P: max. 10%)											
Current consumption	Max. 45mA											
Light source	Infrared LED (940nm)		Infrared LED (850nm)		Red LED (660nm)		Infrared LED (850nm)					
Sensitivity adjustment	Sensitivity adjuster								Fixed			
Operation mode	Selectable Light ON or Dark ON by control wire (white)								Dark ON		Light ON	
Control output	NPN or PNP open collector output • Load voltage: max. 30VDC • Load current: max. 200mA • Residual voltage - NPN: max. 1VDC • PNP: max. 2.5VDC											
Protection circuit	Power reverse polarity protection circuit, output short over current protection circuit											
Indicator	Operation indicator: red LED, Power indicator: red LED (only for emitter of through-beam type)											
Connection	Cable type, connector type											
Insulation resistance	Over 20MΩ (at 500VDC megger)											
Noise immunity	±240V the square wave noise (pulse width: 1μs) by the noise simulator											
Dielectric strength	1,000VAC 50/60Hz for 1 minute											
Vibration	1.5mm amplitude at frequency of 10 to 55Hz (for 1 min) in each X, Y, Z direction for 2 hours											
Shock	500m/s ² (approx. 50G) in each X, Y, Z direction for 3 times											
Environment	Sunlight: max. 11,000lx, Incandescent lamp: max. 3,000lx (receiver illumination)											
Temperature	Ambient temp. -10 to 60°C, storage: -25 to 75°C											
Humidity	Ambient hum. 35 to 85%RH, storage: 35 to 85%RH											
Protection structure	P66 (IEC standard) (BR20M Series: IP67)											
Material	• Case - BRP: Polyamide (black) • BR: Brass, Ni-plate • Sensing part - Polycarbonate Lens				• Case - BRP: Polyamide (black) • BR: Brass, Ni-plate • Sensing part - Polycarbonate Lens				• Case - BRP: Polyamide (black) • BR: Brass, Ni-plate • Sensing part - Polycarbonate Lens			
Cable type	Ø5mm, 4-wire, 2m (emitter of through-beam type: Ø5mm, 2-wire, 2m/receiver: Ø5mm, 3-wire, 2m) (AWG22, core diameter: 0.08mm, number of cores: 60, insulator out diameter: Ø1.25mm)											
Connector type	M12 connector											
Individual	Adjustment screwdriver				Adjustment screwdriver, Reflector (MS-2)							
Accessory	Common				• BR: M18 fixing nut: 2, washer: 1 • BRP: M18 fixing nut: 2				• BR: M18 fixing nut: 4, washer: 2 • BRP: M18 fixing nut: 4			
Approval	CE											
Weight ^{※4}	• BRP: Approx. 140g (approx. 100g) • BR: Approx. 160g (approx. 120g)				• BRP-C: Approx. 70g (approx. 30g) • BR-C: Approx. 90g (approx. 50g)				• BR: Approx. 340g (approx. 300g) • BR-C: Approx. 150g (approx. 110g)			

※1: Non-glossy white paper 50x50mm.
※2: Non-glossy white paper 100x100mm.
※3: The sensing distance is specified with using the MS-2 reflector. The distance between the sensor and the reflector should be set over 0.1m. When using reflective tapes, the reflectivity will vary by the size of the tape. Please refer to the catalog or website.
※4: The weight includes packaging. The weight in parenthesis is for unit only.
※Tightening torque for connector is 0.39 to 0.49N·m.
※The temperature or humidity mentioned in Environment indicates a non freezing or condensation.

Dimensions

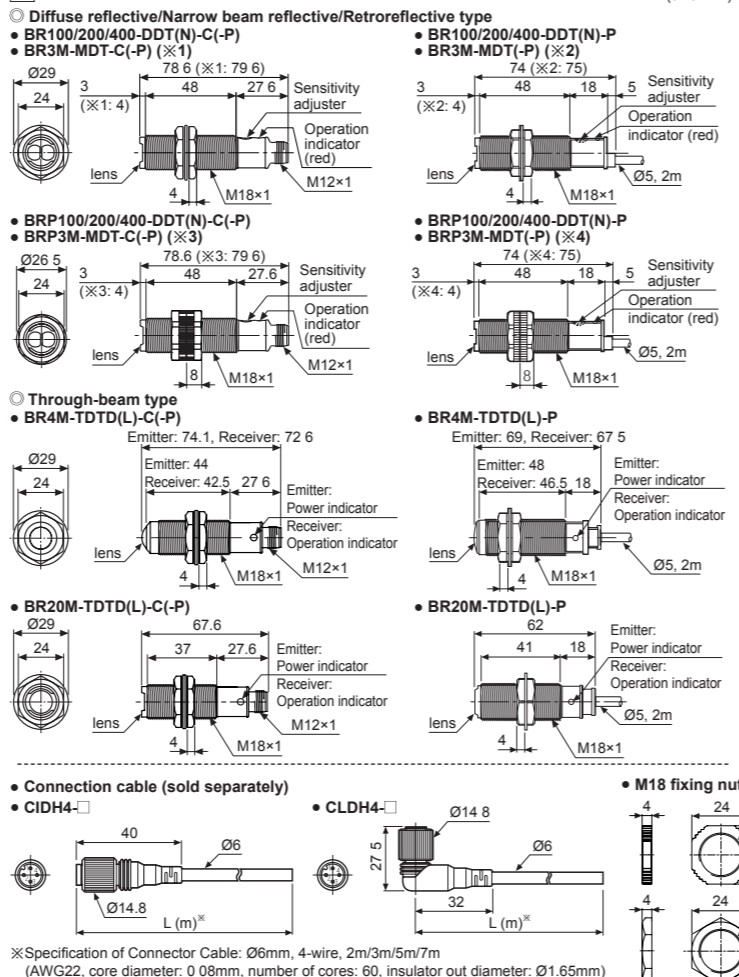

※Specification of Connector Cable: Ø6mm, 4-wire, 2m/3m/5m/7m (AWG22, core diameter: 0.08mm, number of cores: 60, insulator out diameter: Ø1.65mm)

Connections

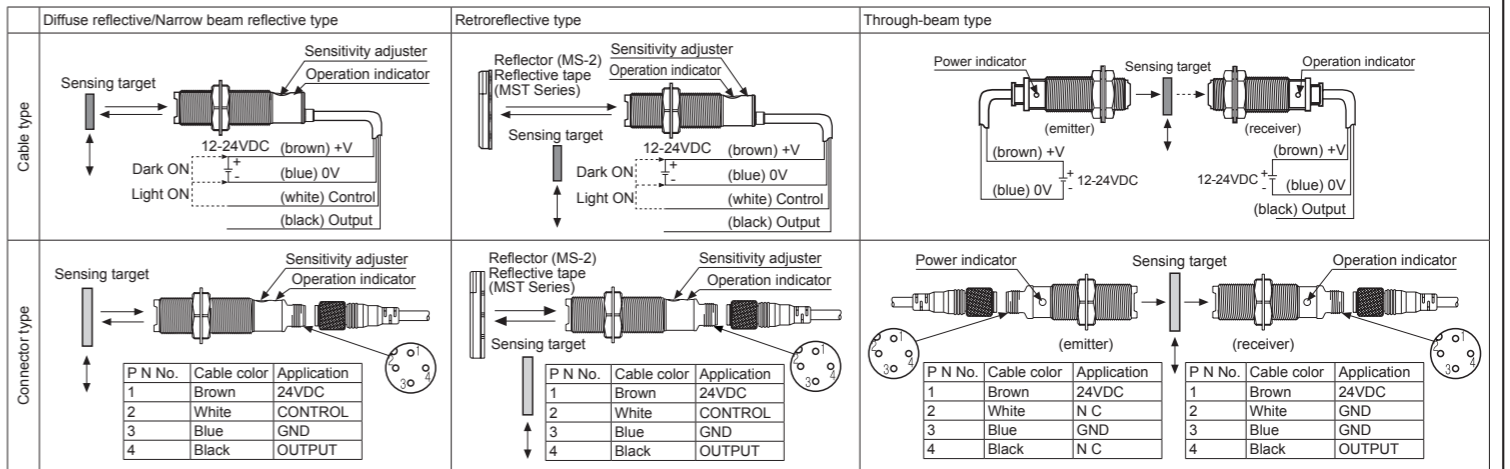

Control Output Circuit Diagram

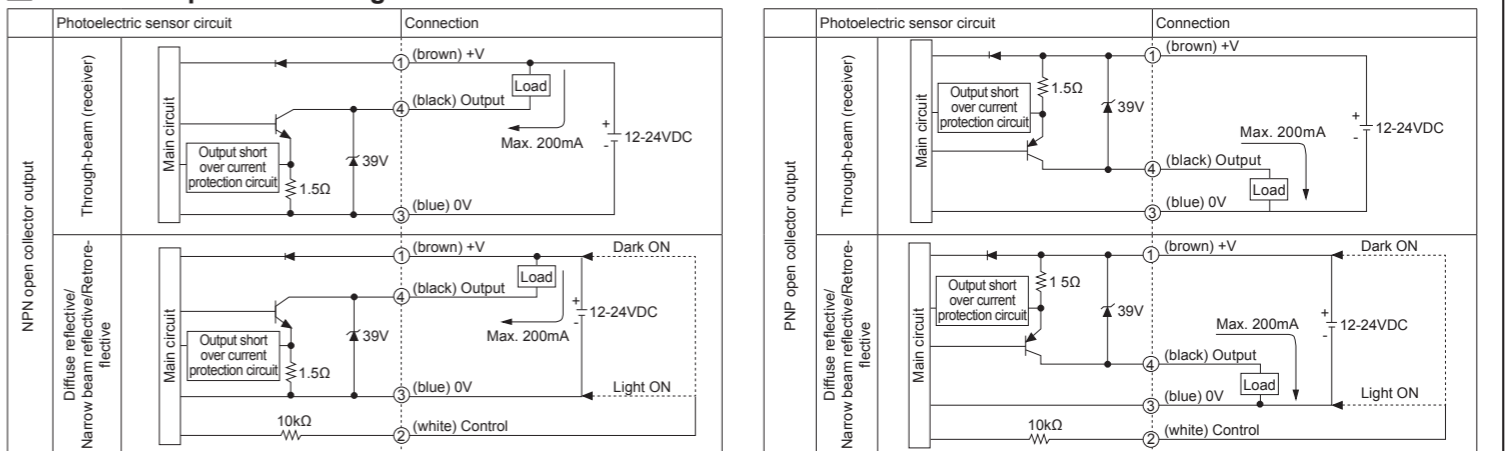

※Before using this unit, select Light ON/Dark ON with control wire. (Light ON: connect control wire with 0V/Dark ON: connect control wire with +V) ※Control wire is only for diffuse reflective/narrow beam reflective/retroreflective type.
※If short-circuit the control output terminal or supply current over the rated specification, normal control signal is not output due to the output short over current protection circuit.

Installation and Sensitivity Adjustment

Install the sensor to the desired place and check the connections. Supply the power to the sensor and adjust the optical axis and the sensitivity as following.
When using photoelectric sensors closely over two units, it may result in malfunction due to mutual interference. When installing the product, tighten the screw with a tightening torque of 0.39N·m for BRP and to 14.7N·m for BR.

Diffuse reflective/Narrow beam reflective type

- The sensitivity should be adjusted depending on a sensing target or mounting place.
- Set the target at a position to be detected by the beam, then turn the Sensitivity adjuster until position ② where the operation indicator turns ON from min. position of the Sensitivity adjuster.
- Take the target out of the sensing area, then turn the Sensitivity adjuster until position ① where the operation indicator turns ON. If the indicator does not turn ON, max. position is ①.
- Set the Sensitivity adjuster at the center of two switching position ①, ②. ※Be sure that it can be different by size, surface and gloss of target.

Retroreflective type

- Supply the power to the photoelectric sensor, after setting the photoelectric sensor and the reflector (MS-2) or reflective tape face to face.
- Set the photoelectric sensor in the position which indicator turns on, as adjusting the reflector or the sensor right and left, up and down.
- Fix both units tightly after checking that the unit detects the target. ※If using more than 2 photoelectric sensors in parallel, the space among them should be more than 30cm.

※If reflectance of target is higher than non-glossy white paper, it might cause malfunction by reflection from the target when the target is near to photoelectric sensor. Therefore put enough space between the target and the photoelectric sensor or the surface of the target should be installed at angle of 30 to 45° against optical axis. (When a sensing target with high reflectance near by, photoelectric sensing with the polarizing filter should be sed.)
※Sensitivity adjustment: Refer to the diffuse reflective/narrow beam reflective type's.

Through-beam type

- Supply the power to the photoelectric sensor, after setting the emitter and the receiver facing each other.
 - Set the receiver in center of position in the middle of the operation range of indicator by adjusting the receiver or the emitter right and left, up and down.
 - After the adjustment, check the stability of operation putting the object at the optical axis.
- ※If the sensing target is translucent body or smaller than Ø15mm, it can be missed by sensor cause light penetrate it.

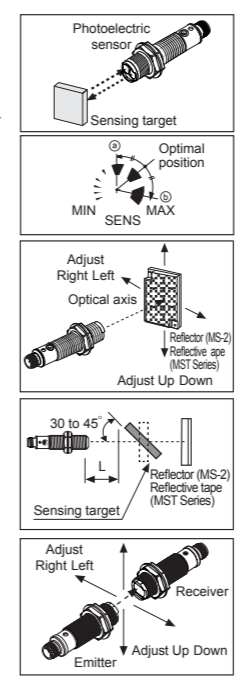

Cautions during Use

- Follow instructions in 'Cautions during Use'. Otherwise, it may cause unexpected accidents.
- When connecting a DC relay or other inductive load to the output, remove surge by using diodes or varistors.
- Use the product, 0.5 sec after supplying power. When using separate power supply for the sensor and load, supply power to sensor first.
- 12-24VDC power supply should be insulated and limited voltage/current or Class 2, SELV power supply device.
- Wire as short as possible and keep away from high voltage lines or power lines, to prevent inductive noise.
- When using switching mode power supply to supply the power, ground F.G. terminal and connect a condenser between 0V and F.G. terminal to remove noise.
- When using sensor with the equipment which generates noise (switching regulator, inverter, servo motor, etc.), ground F.G. terminal of the equipment.
- This unit may be used in the following environments.
 - Indoors (in the environment condition rated in 'Specifications')
 - Altitude max. 2,000m
 - Pollution degree 2
 - Installation category II

Major Products

- Photoelectric Sensors
- Fiber Optic Sensors
- Door Sensors
- Area Sensors
- Proximity Sensors
- Pressure Sensors
- Rotary Encoders
- Connectors/sockets
- Switching Mode Power Supplies
- Control Switches/Lamps/Buzzers
- I/O Terminal Blocks & Cables
- Stepper Motors/Drivers/Motion Controllers
- Graphic/Logic Panels
- Field Network Devices
- Laser Marking System (Fiber, CO₂, Nd: YAG)
- Laser Welding/Cutting System
- Temperature Controllers
- Temperature/Humidity Transducers
- SSRs/Power Controllers
- Counters
- Timers
- Panel Meters
- Tachometer/Pulse (Rate) Meters
- Display Units
- Sensor Controllers